

# Ball Valves and Pneumatic Ball Valves

10B Series: 10,000 psig (690 bar)  
15B Series: 15,000 psig (1034 bar)  
20B Series: 20,000 psig (1379 bar)

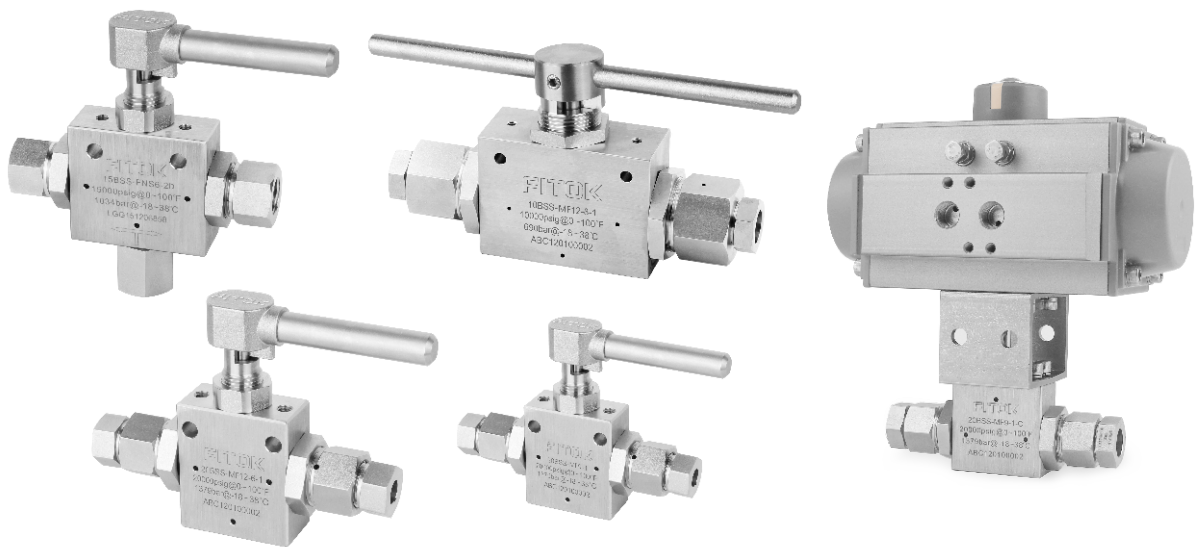

Fittings

Tubing

Quick Couplings

Line Filters

Valves

Sour Service Products

Subsea Valves

Tools and Installation Instructions

Technical Information

Part Number Crossover Charts

# Contents

Features	E-04
Pressure vs. Temperature Curve	E-04
Flow Configuration	E-04
Standard Materials of Construction	E-05
Dimensions	E-07
Panel Mounting Dimensions	E-07
Ordering Information and Dimensions	E-08
Ordering Number Description	E-10

Fittings

Tubing

Quick Couplings

Line Filters

Valves

Sour Service Products

Subsea Valves

Tools and Installation Instructions

Technical Information

Part Number Crossover Charts

## Features

- Working pressure up to 20,000 psig (1379 bar)
- Fluorocarbon FKM O-ring for operation from 0°F to 400°F (-17.8°C to 204°C); other O-ring materials available
- High tensile 316 Stainless Steel as body material
- PEEK seats offer excellent resistance to chemicals, heat and abrasion
- Trunnion mounted stem design
- Full-port flow path to minimize pressure drop
- 2-way and 3-way valve configurations
- Bidirectional flow for 2-way valves
- Wide selection of tube and pipe end fittings available
- Pneumatic actuator optional with air pressure from 80 psig to 116 psig (5.5 bar to 8 bar)

## Pressure vs. Temperature Curve

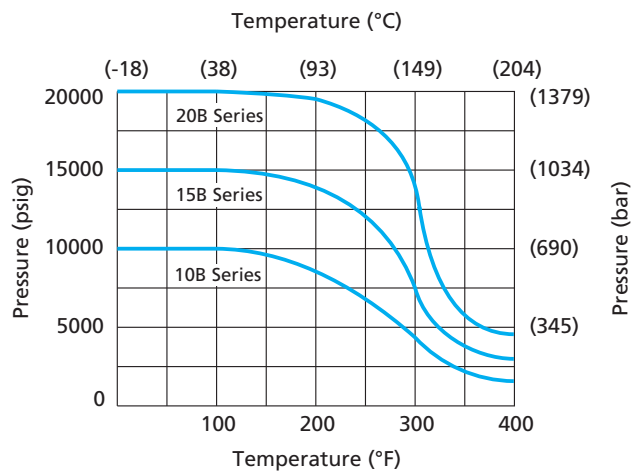

## Flow Configuration

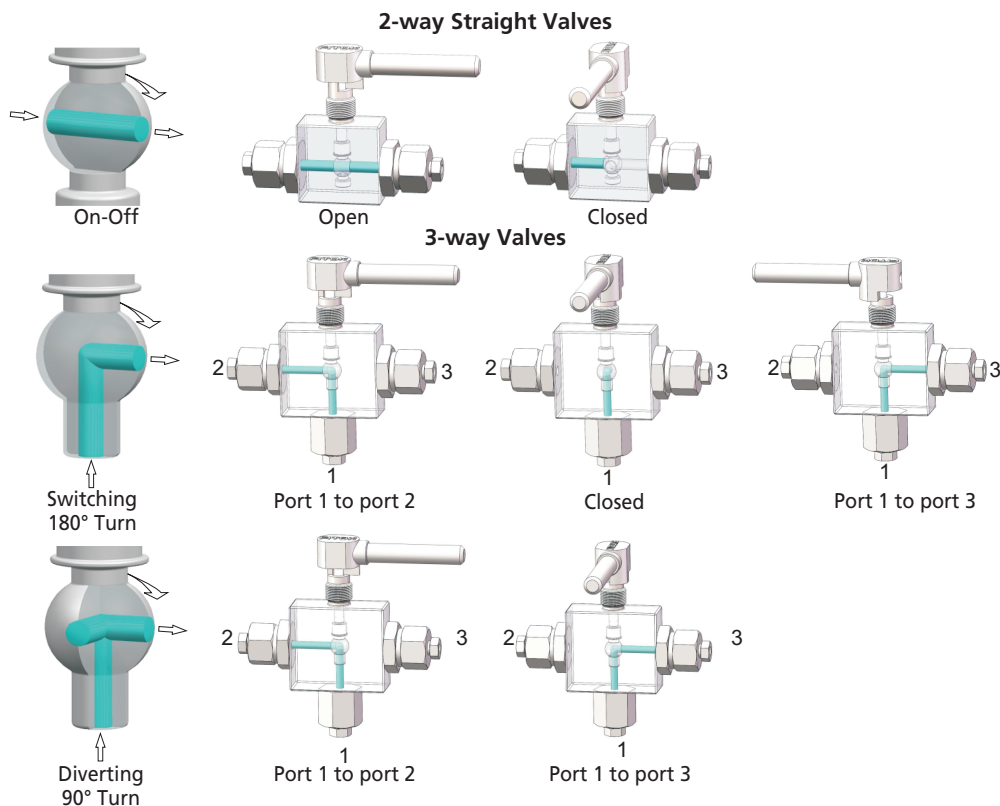

NOTE: The maximum allowable working pressure drops if the side connection works as inlet.

## Standard Materials of Construction

2-way Straight Valves

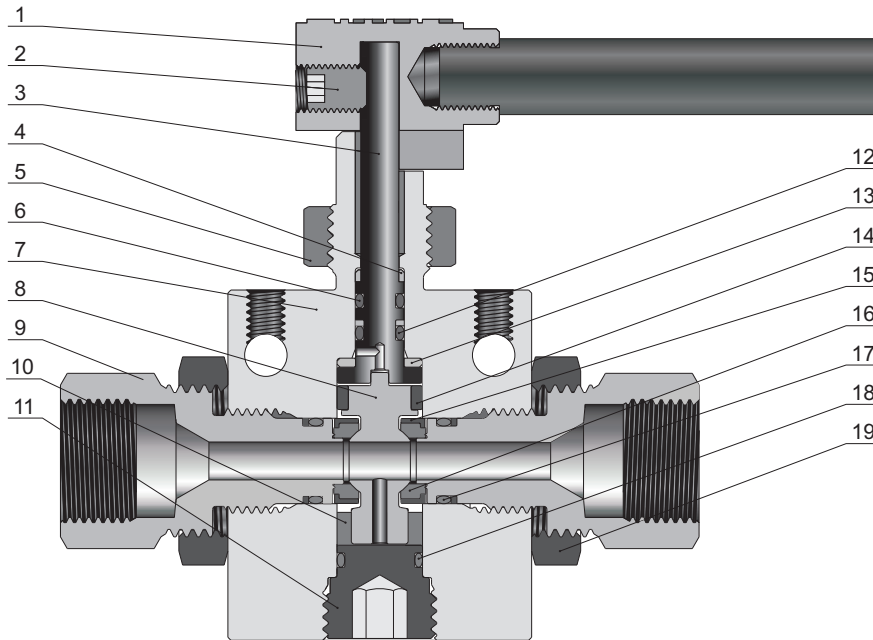

Item	Component	Material Grade
1	Handle	Stainless Steel
2	Set Screw	Stainless Steel
3	<i>Stem</i>	316 SS
4	Stem Backup	PEEK
5	Panel Nut	316 SS
6	Stem O-Ring	Fluorocarbon FKM
7	<i>Body</i>	316 SS
8	<i>Ball</i>	316 SS
9	<i>Seat Gland</i>	316 SS
10	<i>Ball Bearing</i>	PEEK
11	<i>Plug</i>	316 SS
12	<i>Stem O-Ring</i>	Fluorocarbon FKM
13	<i>Thrust Washer</i>	PEEK
14	<i>Ball Bearing</i>	PEEK
15	<i>Seat Retainer</i>	316 SS
16	<i>Seat</i>	PEEK
17	<i>Seat Gland O-Ring</i>	Fluorocarbon FKM
18	<i>Plug O-Ring</i>	Fluorocarbon FKM
19	Lock Nut	316 SS
Lubricant		Molybdenum Disulfide/Fluorinated-based

*Wetted components listed in italics.*

Fittings
Tubing
Quick Couplings
Line Filters
Valves
Sour Service Products
Subsea Valves
Tools and Installation Instructions
Technical Information
Part Number Crossover Charts

Fittings  
Tubing  
Quick Couplings  
Line Filters  
Valves  
Sour Service Products  
Subsea Valves  
Tools and Installation Instructions  
Technical Information  
Part Number Crossover Charts

3-way Valves

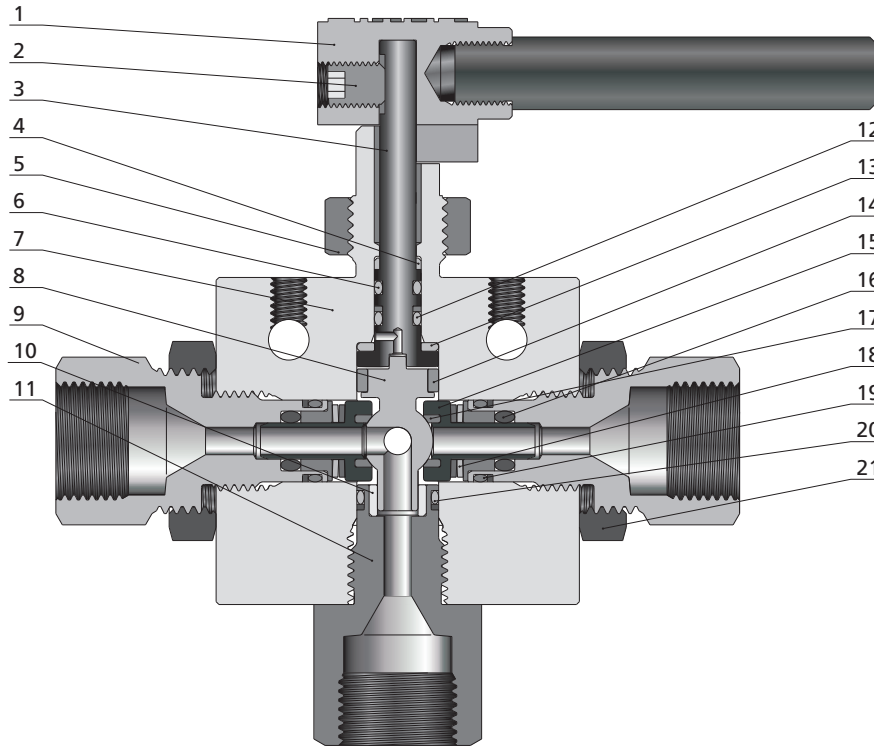

Item	Component	Material Grade
1	Handle	Stainless Steel
2	Set Screw	Stainless Steel
3	Stem	316 SS
4	Stem Backup	PEEK
5	Panel Nut	316 SS
6	Stem O-Ring	Fluorocarbon FKM
7	<i>Body</i>	<i>316 SS</i>
8	<i>Ball</i>	<i>316 SS</i>
9	<i>Seat Gland</i>	<i>316 SS</i>
10	<i>Ball Bearing</i>	<i>Copper Alloy</i>
11	<i>Bottom Gland</i>	<i>316 SS</i>
12	<i>Stem O-Ring</i>	<i>Fluorocarbon FKM</i>
13	<i>Thrust Washer</i>	<i>PEEK</i>
14	<i>Ball Bearing</i>	<i>PEEK</i>
15	<i>Seat Retainer</i>	<i>S17400</i>
16	<i>Seat</i>	<i>Carbon Filled PEEK</i>
17	<i>Seat Retainer O-Ring</i>	<i>Fluorocarbon FKM</i>
18	<i>Belleville Washer</i>	<i>S17700</i>
19	<i>Seat Gland O-Ring</i>	<i>Fluorocarbon FKM</i>
20	<i>Bottom Gland O-Ring</i>	<i>Fluorocarbon FKM</i>
21	Lock Nut	316 SS
	Lubricant	Molybdenum Disulfide/Fluorinated-based

*Wetted components listed in italics.*

## Dimensions

2-way Straight Valves

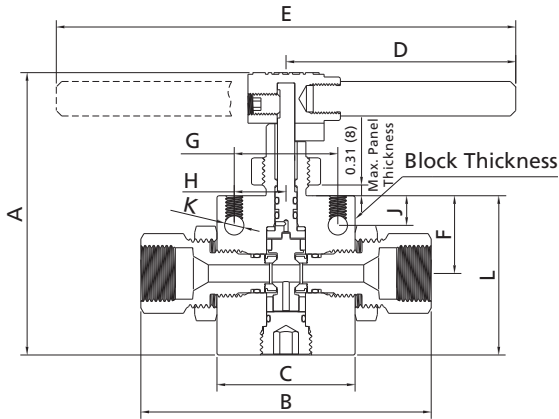

3-way Valves

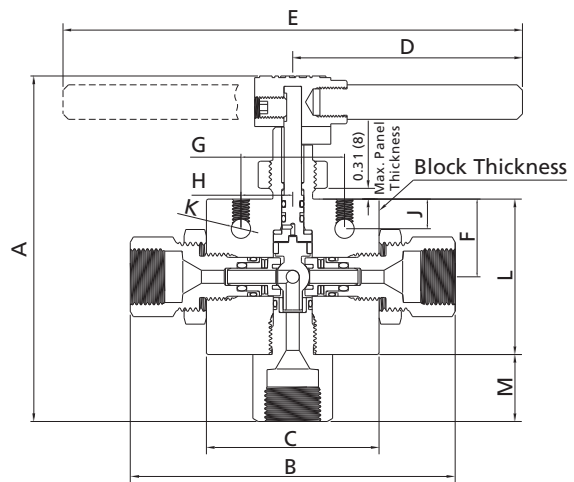

Flow Pattern	Orifice	Dimensions, in. (mm)												Block Thickness
		A	B	C	D	E	F	G	H	J	K	L	M	
2-way	1/4"	4.09 (103.9)	4.19 (106.5)	2.00 (50.8)	3.33 (84.5)	/	1.13 (28.6)	1.50 (38.1)	0.75 (19.1)	0.43 (10.9)	0.28 (7.1)	2.31 (58.6)	/	1.00 (25.4)
	3/8"	4.84 (121.0)	5.53 (140.3)	3.00 (76.2)	4.96 (126.0)	/	1.38 (34.9)	2.00 (50.8)	1.00 (25.4)	0.41 (10.3)	0.28 (7.1)	2.95 (74.9)	/	1.38 (34.9)
	1/2"	5.39 (136.8)	7.73 (196.5)	4.12 (104.6)	/	10.25 (260.0)	1.66 (42.2)	3.00 (76.2)	1.50 (38.1)	0.50 (12.7)	0.28 (7.1)	3.52 (89.4)	/	1.75 (44.5)
3-way	3/16"	5.00 (127.0)	4.70 (119.5)	2.50 (63.5)	3.33 (84.5)	/	1.13 (28.6)	1.50 (38.1)	0.75 (19.1)	0.43 (10.9)	0.28 (7.1)	2.25 (57.2)	0.48 (12.3)	1.00 (25.4)
	3/8"	5.88 (149.3)	5.53 (140.3)	3.00 (76.2)	4.96 (126.0)	/	1.38 (34.9)	2.00 (50.8)	1.00 (25.4)	0.41 (10.3)	0.28 (7.1)	2.87 (73.0)	1.89 (30.2)	1.38 (34.9)
	1/2"	6.91 (175.6)	7.77 (197.4)	4.12 (104.6)	/	10.25 (260.0)	1.66 (42.2)	3.00 (76.2)	1.50 (38.1)	0.50 (12.7)	0.28 (7.1)	3.34 (84.9)	1.70 (43.2)	1.75 (44.5)

NOTE: All dimensions are for reference only and are subject to change.

## Panel Mounting Dimensions

Flow Pattern	Orifice	Dimensions, in. (mm)			
		A	B	C	D
2-way	1/4"	1.50 (38.1)	0.75 (19.1)	0.75 (19.1)	0.28 (7.1)
	3/8"	2.00 (50.8)	1.00 (25.4)	1.13 (28.6)	0.28 (7.1)
	1/2"	3.00 (76.2)	1.50 (38.1)	1.44 (36.5)	0.28 (7.1)
3-way	3/16"	1.50 (38.1)	0.75 (19.1)	0.75 (19.1)	0.28 (7.1)
	3/8"	2.00 (50.8)	1.00 (25.4)	1.13 (28.6)	0.28 (7.1)
	1/2"	3.00 (76.2)	1.50 (38.1)	1.44 (36.5)	0.28 (7.1)

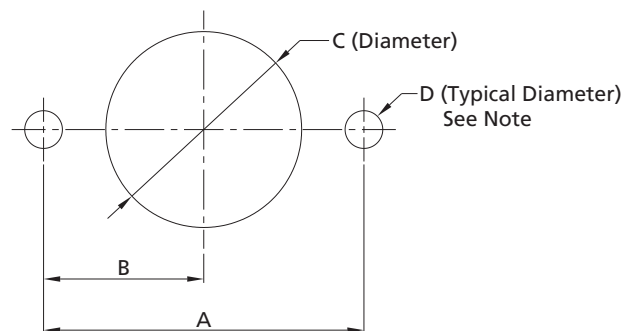

NOTES: 1. Body mounting 1/4-20 thread.  
2. All dimensions are for reference only and are subject to change.

Fittings
Tubing
Quick Couplings
Line Filters
Valves
Sour Service Products
Subsea Valves
Tools and Installation Instructions
Technical Information
Part Number Crossover Charts

## Ordering Information and Dimensions

Ordering Information and Dimensions							
Series	Flow Pattern	Orifice	Connection	Orifice Size in. (mm)	Cv	Ordering Number	Working Pressure psig (bar)
10B	2-way	1/2"	MF12	0.5 (12.7)	10.2	10BSS-MF12-8-1	10,000 (690)
			MF16	0.5 (12.7)	10.2	10BSS-MF16-8-1	
			FNS12	0.5 (12.7)	10.2	10BSS-FNS12-8-1	
			FNS16	0.5 (12.7)	10.2	10BSS-FNS16-8-1	
	3-way	1/2"	MF12	0.5 (12.7)	4.4	10BSS-MF12-8-2	
			MF16	0.5 (12.7)	4.4	10BSS-MF16-8-2	
			FNS12	0.5 (12.7)	4.4	10BSS-FNS12-8-2	
			FNS16	0.5 (12.7)	4.4	10BSS-FNS16-8-2	
			MF12	0.5 (12.7)	4.4	10BSS-MF12-8-2D	
			MF16	0.5 (12.7)	4.4	10BSS-MF16-8-2D	
			FNS12	0.5 (12.7)	4.4	10BSS-FNS12-8-2D	
			FNS16	0.5 (12.7)	4.4	10BSS-FNS16-8-2D	
15B	2-way	1/4"	DFF2	0.094 (2.4)	0.26	15BSS-DFF2-4-1	15,000 (1034)
			DFF4	0.19 (4.8)	1.27	15BSS-DFF4-4-1	
			DFF6	0.25 (6.35)	1.51	15BSS-DFF6-4-1	
			DFF8	0.25 (6.35)	1.51	15BSS-DFF8-4-1	
			FNS2	0.25 (6.35)	1.51	15BSS-FNS2-4-1	
			FNS4	0.25 (6.35)	1.51	15BSS-FNS4-4-1	
			FNS6	0.25 (6.35)	1.51	15BSS-FNS6-4-1	
			FNS8	0.25 (6.35)	1.51	15BSS-FNS8-4-1	
			DFF8	0.375 (9.5)	3.51	15BSS-DFF8-6-1	
		DFF9	0.375 (9.5)	3.51	15BSS-DFF9-6-1		
		FNS4	0.375 (9.5)	3.51	15BSS-FNS4-6-1		
		FNS6	0.375 (9.5)	3.51	15BSS-FNS6-6-1		
		FNS8	0.375 (9.5)	3.51	15BSS-FNS8-6-1		
		1/2"	DFF12	0.5 (12.7)	10.2	15BSS-DFF12-8-1	
			MF12	0.5 (12.7)	10.2	15BSS-MF12-8-1	
			MF16	0.5 (12.7)	10.2	15BSS-MF16-8-1	
			DFF2	0.094 (2.4)	0.13	15BSS-DFF2-4-2	
			DFF4	0.125 (3.2)	0.22	15BSS-DFF4-4-2	
	DFF6		0.19 (4.8)	0.5	15BSS-DFF6-4-2		
	DFF8		0.19 (4.8)	0.5	15BSS-DFF8-4-2		
	FNS2		0.19 (4.8)	0.5	15BSS-FNS2-4-2		
	FNS4		0.19 (4.8)	0.5	15BSS-FNS4-4-2		
	3-way	3/16"	FNS6	0.19 (4.8)	0.5	15BSS-FNS6-4-2	
			FNS8	0.19 (4.8)	0.5	15BSS-FNS8-4-2	
			DFF8	0.33 (8.3)	2.1	15BSS-DFF8-6-2	
			DFF9	0.33 (8.3)	2.1	15BSS-DFF9-6-2	
			MF6	0.2 (5.2)	0.81	15BSS-MF6-6-2	
			MF9	0.31 (7.9)	1.9	15BSS-MF9-6-2	
			DFF8	0.33 (8.3)	2.1	15BSS-DFF8-6-2D	
			DFF9	0.33 (8.3)	2.1	15BSS-DFF9-6-2D	
MF6			0.2 (5.2)	0.81	15BSS-MF6-6-2D		
MF9		0.31 (7.9)	1.9	15BSS-MF9-6-2D			

## Ordering Information and Dimensions (continued)

Series	Flow Pattern	Orifice	Connection	Orifice Size in. (mm)	Cv	Ordering Number	Working Pressure psig (bar)
15B	3-way	3/8"	MF12	0.33 (8.3)	2.1	15BSS-MF12-6-2	15,000 (1034)
						15BSS-MF12-6-2D	
			FNS4	0.33 (8.3)	2.1	15BSS-FNS4-6-2	
						15BSS-FNS4-6-2D	
			FNS6	0.33 (8.3)	2.1	15BSS-FNS6-6-2	
						15BSS-FNS6-6-2D	
			FNS8	0.33 (8.3)	2.1	15BSS-FNS8-6-2	
						15BSS-FNS8-6-2D	
20B	2-way	1/4"	DFF4	0.19 (4.8)	1.27	20BSS-DFF4-4-1	20,000 (1379)
			DFF6	0.25 (6.35)	1.51	20BSS-DFF6-4-1	
			DFF8	0.25 (6.35)	1.51	20BSS-DFF8-4-1	
			MF4	0.11 (2.8)	0.36	20BSS-MF4-4-1	
			MF6	0.2 (5.2)	1.23	20BSS-MF6-4-1	
			MF9	0.25 (6.35)	1.51	20BSS-MF9-4-1	
			HF4	0.094 (2.4)	0.26	20BSS-HF4-4-1	
			HF6	0.125 (3.2)	0.47	20BSS-HF6-4-1	
		3/8"	HF9	0.19 (4.8)	1.05	20BSS-HF9-4-1	
			DFF8	0.375 (9.5)	3.51	20BSS-DFF8-6-1	
			DFF9	0.375 (9.5)	3.51	20BSS-DFF9-6-1	
			MF6	0.2 (5.2)	1.23	20BSS-MF6-6-1	
			MF9	0.31 (7.9)	2.93	20BSS-MF9-6-1	
			MF12	0.375 (9.5)	3.51	20BSS-MF12-6-1	
	3-way	3/16"	DFF4	0.125 (3.2)	0.22	20BSS-DFF4-4-2	
						20BSS-DFF4-4-2D	
			DFF6	0.19 (4.8)	0.5	20BSS-DFF6-4-2	
						20BSS-DFF6-4-2D	
			DFF8	0.19 (4.8)	0.5	20BSS-DFF8-4-2	
						20BSS-DFF8-4-2D	
MF4			0.11 (2.8)	0.17	20BSS-MF4-4-2		
					20BSS-MF4-4-2D		
MF6			0.19 (4.8)	0.5	20BSS-MF6-4-2		
					20BSS-MF6-4-2D		
MF9			0.19 (4.8)	0.5	20BSS-MF9-4-2		
					20BSS-MF9-4-2D		
HF4	0.094 (2.4)	0.13	20BSS-HF4-4-2				
			20BSS-HF4-4-2D				
HF6	0.125 (3.2)	0.22	20BSS-HF6-4-2				
			20BSS-HF6-4-2D				
HF9	0.19 (4.8)	0.5	20BSS-HF9-4-2				
			20BSS-HF9-4-2D				

Ball Valves	Fittings
Ball Valves	Tubing
Ball Valves	Quick Couplings
Ball Valves	Line Filters
Ball Valves	Valves
Ball Valves	Sour Service Products
Ball Valves	Subsea Valves
Ball Valves	Tools and Installation Instructions
Ball Valves	Technical Information
Ball Valves	Part Number Crossover Charts



## Ordering Number Description

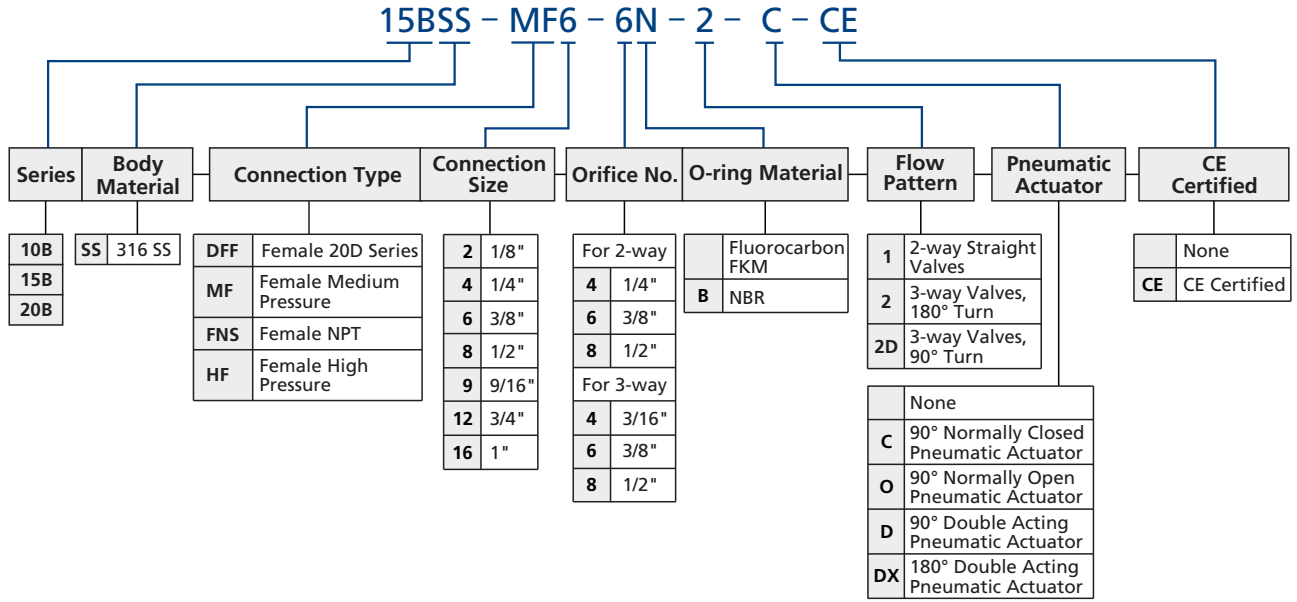

- NOTES: 1. For more details regarding 20D Series and Medium/High Pressure connections, please see **Connection Information** on I-02.
2. "Ordering Number Description" is a reference to understand the combination rules of FITOK product part number. Not all combinations are available.

Code	O-ring Material	Working Temperature Range, °F (°C)
	Fluorocarbon FKM	0 to 400 (-17.8 to 204)
B	NBR	-10 to 250 (-23 to 121)

Fittings
Tubing
Quick Couplings
Line Filters
Valves
Sour Service Products
Subsea Valves
Tools and Installation Instructions
Technical Information
Part Number Crossover Charts